

6' WORKBENCH TWS-1020

Teclab workbenches share common design features that have earned for Teclab the reputation in the industry as the “professional’s bench.” Typical features include an abundance of grounded outlets within easy reach; an infinite variety of drawer and door combinations to meet every job and storage requirement; expansive work surfaces, shelves, and back guards in a choice of task-oriented materials.

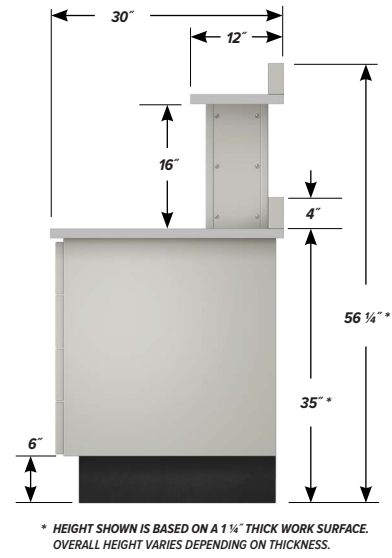
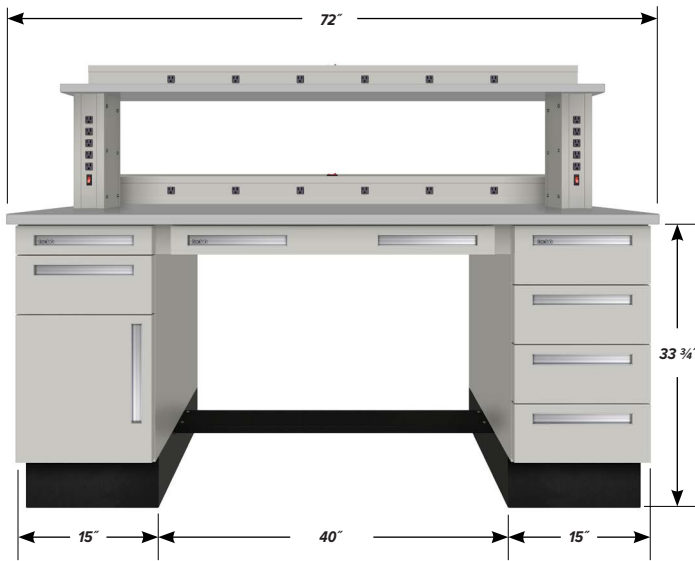

FEATURES

One **C-1527** two drawer, one door 15" wide Base Cabinet

One **C-1522** four drawer 15" wide Base Cabinet

One **FR6-40** 40" Foot Rest

One **APD-3600** 36" wide Apron Drawer

Two **AF-02** 2" Apron Fillers

Two **SS-16-EP-1** 16" tall Shelf Supports with 5 grounded 15A outlets, plus combination circuit breaker rocker switch.

One **TP1-3072-PVC** 30" x 72" x 1 1/4" plastic laminate Work Surface

One **SP1-1272-PVC** 12" x 72" x 1 1/4" Shelf of same material

Two **PBG-72-EP-1** 4" x 72" x 2" Powered Back Guards with 6 grounded outlets, plus combination circuit breaker rocker switch.

FINISH OPTIONS

Powder coated steel components.

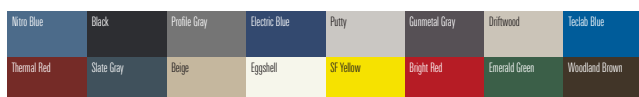

Custom paint color matching is available. Stainless Steel is also available.

WORK SURFACE COLOR OPTIONS

Visual comparison. Color choices vary depending on work surface type.

