

CABINET MOUNTED SHELVING (SUS)



Highest quality. Best built. Most durable. Most versatile. Take your pick. They're all descriptions that have become synonymous with Teclab in the last 30 years. But our fanatical commitment to building the best is more than just talk.

The extraordinary fit and finish of Teclab Cabinet Mounted Shelving reflects that devotion to providing what customers want and need. Customers see our quality in clean, functional lines. They feel it in the solidity of a well made unit. And they experience it in the attention to the smallest of details of design assistance, installation and after-sale service.

Standard horizontal steel shelves have a stiffener formed downward to create a fully flat surface. The stiffener can also be formed upward to create a front shelf retainer.

DIMENSIONS:

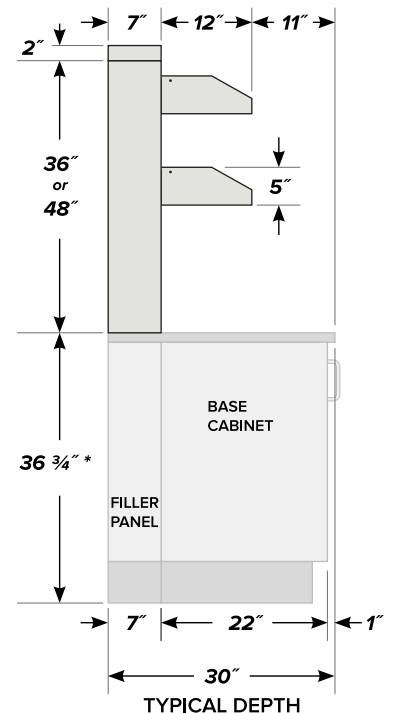
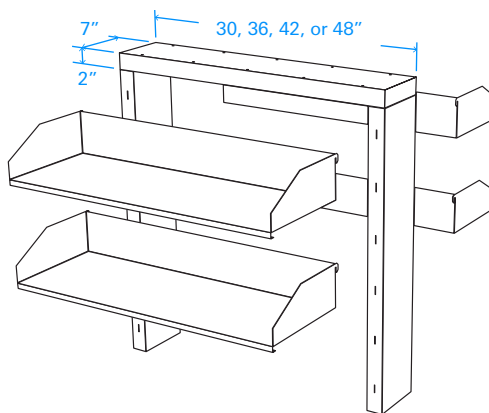

* HEIGHT SHOWN IS BASED ON A 1 1/4" THICK WORK SURFACE. OVERALL HEIGHT VARIES DEPENDING ON THICKNESS

		30" wide	36" wide	42" wide	48" wide
36" high complete unit	single-sided (2 shelves)	SUS-3036-2	SUS-3636-2	SUS-4236-2	SUS-4836-2
	double-sided (4 shelves)	SUS-3036-4	SUS-3636-4	SUS-4236-4	SUS-4836-4
48" high complete unit	single-sided (2 shelves)	SUS-3048-2	SUS-3648-2	SUS-4248-2	SUS-4848-2
	double-sided (4 shelves)	SUS-3048-4	SUS-3648-4	SUS-4248-4	SUS-4848-4
36" high complete unit with Electric Kit	single-sided (2 shelves)	SUS-3036-2-EP	SUS-3636-2-EP	SUS-4236-2-EP	SUS-4836-2-EP
	double-sided (4 shelves)	SUS-3036-4-EP	SUS-3636-4-EP	SUS-4236-4-EP	SUS-4836-4-EP
48" high complete unit with Electric Kit	single-sided (2 shelves)	SUS-3048-2-EP	SUS-3648-2-EP	SUS-4248-2-EP	SUS-4848-2-EP
	double-sided (4 shelves)	SUS-3048-4-EP	SUS-3648-4-EP	SUS-4248-4-EP	SUS-4848-4-EP

PD - SUS - v.1.3